



Translation of the original instructions

RÜHLE - Miknetum

Type: MPR 400

Table of Contents

1	Safety Instructions.....	3
1.1	Safety instructions	3
1.2	Remaining risk of accidents	6
1.3	Intended Use.....	7
2	Installation instructions	7
2.1	Machine transport and setup	8
2.2	Workplace description.....	8
2.3	Connecting the machine	9
3	Operating instructions.....	9
4	Cleaning instructions.....	12
4.1	Safety instructions	12
4.2	Cleaning agents and disinfectants.....	13
4.3	Cleaning procedure.....	13
5	Service: Care, maintenance, repair.....	14
5.1	Regular care	14
5.2	Regular maintenance.....	15
5.3	Repair and spare parts	16
6	Disposal.....	16
7	Technical documentation	17
7.1	Technical data	17
7.2	Electrical circuit diagram	17
8	EC Declaration of Conformity according to Directive 2006/42/EC.....	18

Status: 11/10/2016

Changes reserved

1 Safety Instructions

!!! Observe the safety instructions during the installation, operation, cleaning and maintenance of the Rühle Miknetum!



Hazard potentially causing irreversible injuries if disregarded.



Warning, potentially causing serious injuries if disregarded.



Note



Work on electrical equipment of the machine may only be carried out by qualified technicians!



Always disconnect machine from the mains during this process!



Refrigeration installer

These work activities may be carried out only by a refrigeration installer! Disregard may result in injuries.



Warning of hot surface.



Warning of suspended load.

1.1 Safety instructions

!!! A **supervisor** (responsible person) must be appointed for the machine!

This person must:

- a) Completely read and understand these operating instructions before transport, commissioning, setup, operation, cleaning, decommissioning, care / maintenance as well as dismantling / disposal!
- b) Prepare work instructions for the intended and safe transport, commissioning, setup, operation, cleaning, decommissioning, care / maintenance as well as dismantling / disposal!

missioning, care / maintenance as well as dismantling / disposal!

- c) Make sure that the qualified workers have completely read and understood the respective work instructions according to section 1.1b!
- d) Proper functioning of the protective devices must be checked at least once a year by a Rühle service technician!
- e) Provide personal protective equipment!

All life cycles phases:



Wear foot protection!



Wear hand protection!



Wear protective clothing!

Cleaning; care / maintenance; dismantling:



Wear eye protection!



Use light breathing mask!

Care / maintenance:



Wear hearing protection!

!!! The **operator** must operate the machine according to the intended use and strictly observe all points listed in the "Operation" work instructions prepared by the supervisor.

!!! Before putting the machine into operation for the first time and on each working day, the **operator** must check the functionality of the following safety devices:

- a) Visual check for changes or damages on all machine sides and accessible machine parts, e.g. steel cables and chain. The machine must be shut down in the event of any damages or changes!
- b) Check the safety switches as follows:
 - Start the machine. - Press the emergency-stop switch. - If the machine has not switched off, it must be shut down immediately!

!!! To **shut down** the machine, the emergency-stop switch must be pushed to "Emergency-Stop", the main switch turned to "0" - OFF" and the power plug pulled from the outlet! Take the Table PC from the bracket and switch it off permanently. The machine must be secured against further use!

!!! The **supervisor** must arrange for the repair of the non-functional safety device by a Rühle service technician. Until the corresponding parts have been repaired, the supervisor must ensure that the machine or parts of the machine are under no circumstances put into operation!

!!! The **cleaning personnel** must observe the work procedures from the "Cleaning" work instructions prepared by the supervisor.

!!! The **maintenance personnel** may only carry out work specified as "Regular care", unless any other authorisation has been issued in writing by the manufacturer of the machine. The maintenance personnel must observe the work procedures from the "Maintenance" work instructions prepared by the supervisor.

The power plug must be disconnected for maintenance work!

!!! The machine may not be modified.

!!! Only Rühle spare parts and accessories may be used.

!!! The operating instructions as well as all other technical documents included must be supplied completely when reselling the machine.

1.2 Remaining risk of accidents

!!! All life cycles phases



Error messages of the operating system must be heeded!
Non-compliance is strictly prohibited!

There is a risk of crushing between motor protection and machine base cover. Staying in the swivel range of the drum is therefore strictly prohibited!

!!! All life cycles phases



Work on the cooling unit and cooling system may only be carried out by a refrigeration installer!

!!! All life cycles phases



Staying beneath the lifting aid (standard trolley support) and reaching into the area of moving parts is strictly prohibited. The standard trolleys provided must be used!

!!! Maintenance



The machine must be disconnected from the mains when performing maintenance work!



The protective covers may be removed only while performing maintenance (control cabinet, side cover)!



Beware of hot or cold surfaces, e.g. drives, cooling, unit, etc., during maintenance work!

1.3 Intended Use

The Miknetum has been solely designed for mixing, salting/seasoning, marinating and tumbling meat products and salads. The max. room temperature may be 12 °C for reasons of food hygiene!

This machine is designed to be operated by

- a person over the age of 18!
- only one tablet PC with the application software (Rühle MPR App)!



Claims of any type because of damages due to non-intended use are ruled out!

Misuse:

- Any use other than the one listed above is strictly prohibited and is considered misuse!
- Operating the machine in explosion hazard areas is prohibited!
- Handling / processing products and materials not belonging to food products is prohibited!
- The lifting aid may be used only for the standard trolleys provided and must not be overloaded! Lifting of persons is strictly prohibited!
- Connecting several tablet PCs with a machine is prohibited!

2 Installation instructions

Installation and commissioning of the machine may only be carried out in the presence of a Rühle service technician or by persons authorised by Rühle.

Rühle GmbH Lebensmitteltechnik shall not be liable for any damage resulting from non-compliance with these operating instructions.

2.1 Machine transport and setup

Please refer to the short instructions supplied with the machine regarding transport and setup of the Miknetum.



The machine and machine parts must be transported by 2 persons (1x operator of floor conveyor / 1x transport supervision).

The power supply line must not be damaged by driving over or pinching it!

The machine must be decommissioned until a damaged power supply line has been repaired!



Make sure the machine is stable!

Make sure the machine bases have contact with the setup surface and are then tightened!

Ensure that the max. filling quantity of 400 kg per standard trolley is not exceeded!

2.2 Workplace description

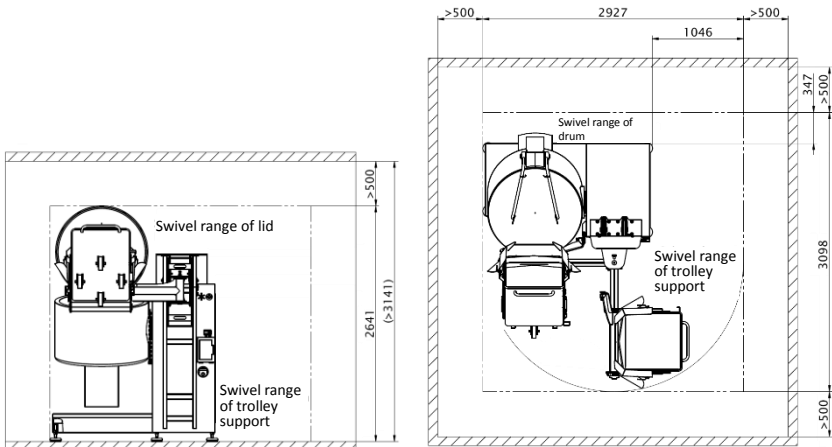

The work area around the machine is at least 0.5 m on all sides; for maintenance work it is at least 1 m; if used as passage way, it is at least 1.2 m.

2.3 Connecting the machine

The machine is connected to a three-phase current outlet; its data (voltage, amperage) must agree with the specifications on the type plate of the machine.



The machine must be decommissioned until a damaged power supply line has been repaired!

The power supply line must be regularly checked!

Check the correct rotational direction of the machine by starting it. A message appears on the tablet PC if the rotating field is wrong.



- In such a case, an electrician must change the direction of rotation inside the mains plug.
- The power supply to the machine must be fuse-protected with 32 A secured with an AC/DC sensitive ground-fault circuit interrupter (type B).

3 Operating instructions

Please refer to the short instructions supplied with your machine for the operation of your Miknetum.



Follow also the safety instructions in Chapter 1.1!

Make sure that you are connected to the right machine with your tablet PC!



Depending on the application programs, the drum is moved automatically. While the program is running, no person may stand within the working range of the machine (front distance at least 1.2 m over the entire machine width).

When the drum moves automatically a 5 second starting alert (horn) sounds.

If the power fails when a user program is being executed the machine will react as follows when the power supply is reinstated: it will start up again automatically and the program will continue from that point at which it was interrupted by the power failure. The startup warning (horn) will sound before this restart.

In its respective life cycle phases (transport, commissioning, setup, operation, cleaning, decommissioning, care / maintenance, dismantling / disposal) this machine is designed for 1-person operation!

When using this machine, no other person may be present near the machine. The exception (2-man operation):

- Installation and removal of lid
- Installation and removal of lid holder
- Installation and removal of tumbling arm
- Installation and removal of mixing arm
- Installation and removal of standard trolley support
- Installation and removal of protective gearbox cover
- Transport of machine and machine parts
- Maintenance work inside the drum



Depending on the user programs, temperatures down to -25°C may be generated in the drum. Take the corresponding precautions.

Do not touch the tumbling arm / mixing arm with your hands or any object when they are moving! Their rotational speed while the lid is open is restricted for safety reasons!

Make sure before each lifting operation that the standard trolley sits correctly in the standard trolley support of the lifting aid and that it is locked!

No person may be present in the swivel range of the drum!

The drum can only be swivelled after the lifting aid has moved to the bottom. Prior to starting a recipe, the lifting aid must therefore be moved down again!

When emptying the drum corresponding appropriate precautions must be taken to ensure that no person stands in the discharge area of the machine!



Make sure when mounting (or adjusting) the tumbling arm, mixing arm (alternative blind plug), standard trolley support as well as the chain on it that the pertaining locking pins are correctly locked!

No person may stand in the swivel range of the lid!



The operator must make sure that no persons, who do not know the hazards of the machine or cannot anticipate them, are about in the area of the machine!

If the drum is inclined downwards and you aerate the drum or even open the lid, the goods will fall out of the machine.

Each time before you start working, make sure that the lid seal has been inserted correctly. For this, check during program start whether a pressure loss is indicated on the pressure display (if the machine can create a vacuum). If this is the case, the gasket has been mounted correctly. Otherwise check the gasket.



Please refer to the short instructions supplied with your machine regarding the manual operation of the manual switch control.

The lid cannot be opened when there is a vacuum in the machine or if it has not yet been fully aerated.

If you interrupt a program by pressing "Pause", you will be prompted to aerate when "Open lid" is actuated. Only after the drum has been evacuated will you be able to open the lid by actuating it again.

You can aerate the machine in a program.

The drum can be set to any position between 30° and 102° (= discharging position) so that it can be used for any operating process.

The tablet PC may only be operated by touching it with the fingers. Using any objects (e.g. blade) is prohibited!

4 Cleaning instructions

The Miknetum has been designed to allow for complete cleaning of all parts that come into contact with the food product.

4.1 Safety instructions

- Follow also the safety instructions in Chapter 1.1!
- The cleaning staff must notify the supervisor immediately of any defects on the machine!
- The cleaning staff must use the specified cleaning agents and disinfectants!
- Germ reduction is achieved only by correct cleaning and subsequent disinfection!
- Appropriate material (e.g. brushes, rags, ...) is required and must be provided for the proper procedures of the above!
- Cleaning products and disinfectants approved for the food product area and suitable against contamination (e.g. protein, lime-scale, ...) must be used!
- The cleaning agents and disinfectants must be prepared to a solution as described in the product data sheet of the manufacturer!
- Personal protective equipment must be worn!



Cleaning with high-pressure cleaners

is permitted only for:

- all outside surfaces,
- drum,
- lid and lid seal,
- intake filter and air intake pipe,
- tumbling arm,
- mixing arm and
- blind plug

The tablet PC and its holder must be cleaned manually and not exposed to any water jet!



All other parts and surfaces may be cleaned only with normal water pressure!

4.2 Cleaning agents and disinfectants

The following cleaning agents and disinfectants must be used:

Cleaning agents:	Alkaline cleaning:	P3 - topax 12, P3 - topax 19, P3 - topax 66
	Acidic cleaning:	P3 - topax 56
Disinfectants:		P3 - topax 91, P3 - topax 99
Supplier:		Henkel Hygiene GmbH Bonner Str. 117 D-40589 Düsseldorf Tel.: +49 211-9893-0

Or:

Cleaning agents:	Alkaline cleaning:	Somplex F fat solvent
	Acidic cleaning:	Somplex foam, acidic
Disinfectants:		Tego 2000, Tego IMC
Supplier:		Th. Goldschmidt AG Goldschmidtstr. 100 D-45116 Essen Tel. +49 201-1730-1

4.3 Cleaning procedure

Please refer to the short instructions supplied with your machine for carrying out the cleaning procedure.

Cleaning preparations:

- To ensure optimum cleaning, some components of the machine must be removed.
- Remove the mixing arm and the tumbling arm from the drum!
- Simply pull off the stripper rubber at the tumbling arm from the outside to the inside.
- Pull the lid seal off the inside of the lid!
- Remove the intake filter at the upper lid edge out of the bracket!

- Remove the tablet PC from the holder and close it. Fold up the holder!

5 Service: Care, maintenance, repair

Any work related in any way with service may be carried out only by Rühle service technicians and by persons authorised by Rühle in writing. In this regard, a distinction is made between regular care and maintenance and repair. The respective qualification certificate must be issued explicitly for the corresponding work.



Follow also the safety instructions in Chapter 1.1!



Only qualified technicians may carry out repairs on the cooling system of the machine!



Notify and obtain permission from Rühle customer service if welding or cutting work is required on the machine!



Make sure when working on the electrical equipment of the machine that

- this is only done by qualified personnel!
- the machine is always disconnected from power!
- a waiting time of at least 10 minutes is observed after switching off the machine to allow the capacitors of the frequency converters to discharge to a harmless voltage level!



5.1 Regular care

Regular care of the machine must be carried out at least once per week. This prevents malfunctions and signs of wear.

Any abnormalities detected during regular care must be reported to the supervisor! He must immediately initiate correction or maintenance or notify Rühle Service!

Care schedule:

- a) Disassemble the machine according to the cleaning instructions. Check for any parts moving with difficulty, material abrasion or other signs of wear and tear.
- b) Check hygienic condition and function of lid seal!
- c) Check function and firm seating of the closures at the tumbling and mixing arms (or blind plugs) as well as the lifting aid!
- d) Check hygienic condition of the stripper rubber on the tumbling arm!
- e) Clean air intake pipe thoroughly!
- f) Check the drum positioning; contact Rühle service if necessary!
- g) Check the lifting aid (standard trolley support)!
- h) Check the lid holder!
- i) Check the chain lock for flawless function!
- j) Visually check the chain for wear!
- k) Visually check the steel cable for fraying!

5.2 Regular maintenance

Regular maintenance of the machine must be carried out every 2000 hours of operation but at least once per year.

Maintenance schedule:

- a) Inspect the safety devices as outlined in Chapter 1.1 Safety Instructions!
- b) Test run with open machine (caution: moving parts)!
- c) Check air filter and air oil separator of the vacuum pump and replace, if necessary!
- d) Change oil of the vacuum pump!

- e) Check cooling performance of the cooling unit; service, if necessary, and clean condenser!
- f) Check function of pressure transmitters and temperature sensors!
- g) Inspect the hoses (vacuum system)!
- h) Check radial shaft seals for leak tightness; replace otherwise!
- i) Read the error memory (frequency converter)!

5.3 Repair and spare parts

As a damaged part on a machine is usually damaged due to causes unrelated to the part, always carry out a fault diagnosis.

For this reason, contact our Service Hotline at +49 7748-523-11 for spare parts or technical faults. Please keep the machine type and number ready.

6 Disposal

1. The machine contains a cooling system filled with the refrigerant R404A. It must be pumped off by a refrigeration installer and must then be disposed of correctly!
2. The following components contain oil:
 - a. Lid drive
 - b. Tumbling arm drive
 - c. Mixing arm drive
 - d. Slewing gear
 - e. Lifting aid drive
 - f. Vacuum pump
 - g. Compressor (cooling unit)

All gears/motors except for the compressor are equipped with oil draining screws. The compressor must be drilled open for draining the oil. Subsequently, dispose of the oil properly!

3. All other materials must be sorted and disposed of at a recycling facility!

7 Technical documentation

7.1 Technical data

Connection voltage:	400 V 50/60 Hz 3-phase AC / N / PE
Power consumption:	8.8 kW
Full-load current:	18.1 A
Back-up fuse max.:	32 A
Protection class:	IP54
Ambient temperature:	+2 to 40 °C
Dimensions, W x H x D:	2927 x 2641 x 3098 mm
Machine weight:	1400 kg
Transport weight:	1700 kg
Container size:	400 litres
Max. filling:	300 litres
Refrigerant:	R404A, 0.76 kg
Mixing arm speed:	-25 to +25 rpm
Tumbling arm speed:	0 to +25 rpm
Vacuum:	0 - 90 %
Lifting aid, load capacity:	400 kg
Emission sound pressure level:	$L_{pA} \leq 70$ dB(A)
Measured according to:	DIN EN ISO 11201 accuracy class 2
Measured:	while idling without product, at maximum speed

The data on the type plate principally applies; it is located at the rear of the machine next to the power supply line. In case of deviations contact the manufacturer for a written confirmation of the data!

If your country requires a ground fault circuit interrupting device as protective measure, a ground fault circuit interrupting device (type B), AC/DC sensitive, must be used.

7.2 Electrical circuit diagram

The electrical circuit diagram of your machine is located in the electrical control cabinet and must be supplied when reselling the machine!